



AVK SERIES 36/80 GATE VALVE WITH PE PIPES INSTALLATION, OPERATION & MAINTENANCE MANUAL

Instruction for use

Thank you for selecting an AVK product. With correct use, the product is guaranteed to deliver a long and reliable service. This manual has been prepared to assist you with the installation, operation and maintenance of the valve to the maximum efficiency. For ease of reference, it has been divided into sections covering all aspects of use, and it is in the users best interests to read it and ensure that it is fully understood.

Health and Safety

It is always recommended that wherever work is being carried out on a valve that the valve is fully depressurised prior to carrying it out, and for the convenience draining of the line may be beneficial.

It is essential that the user of the valve is aware of the weight of the components and/or assemblies that must be handled and manipulated during installation and maintenance. It is the users responsibility to ensure that safe working practices are followed at all times.

Whenever AVK products are installed, operated, or maintained, it is essential that the staff that undertake these operations be adequately trained. The hazards of pressurised liquids and gases can be severe, and it is the responsibility of the users to ensure that trained, competent staff undertake these duties. This manual has been designed to assist, but it can never fully replace quality training in the workplace. AVK technical staff will always be available to answer any questions relating to specific problems that may not be covered by this manual.

AVK products are designed and manufactured to be fit for purpose, and to a high and reliable standard. This provides a safe product with minimum risk to health when used correctly for the purpose for which it was designed. However, this assumes that the equipment is used and maintained in accordance with the manual, and the user is advised to study this manual, and to make it available to all staff that may need to refer to it.

AVK cannot be held responsible for any incidents arising from incorrect installation, operation or maintenance. The responsibility for this must rest wholly with the user.

AVK SERIES 36/80 GATE VALVE WITH PE PIPES INSTALLATION, OPERATION & MAINTENANCE MANUAL

1. Introduction

Series 36/80 gate valves are fitted with PE100 pipe to enable the use of electrofusion coupling or butt welding. The gate valve is fitted with a one piece bonnet requiring no maintenance and are available from DN80 (pipe OD 90mm) to DN300 (pipe OD 315mm).

2. Installation

Ensure pipe ends are clear of foreign objects. Connection of PE pipe is to be carried out in accordance with correct procedures given by manufacturers' manual.

3. Operation

Series 36 valves are suitable for use with clean water or neutral liquids up to 70°C. Minimum liquid temperature must be above freezing. Insulation is essential for external temperatures on 0°C to - 10°C. The valves can be operated manually by either ring key and bar, tee key, handwheel, gearbox or electric actuation. Direction of closing is on top of the stem cap. Red disc for CC and white disc for ACC.

Materials:

Castings (body, bonnet & stem cap)

Ductile Iron

Coating

Fusion bonded epoxy (FBE)

Stem & bonnet bolts

Stainless Steel

Wedge

Ductile Iron, with EPDM rubber

Shrink hose

Plastic

Pipes

PE

Refer to datasheets for specific information



AVK SERIES 36/80 GATE VALVE WITH PE PIPES INSTALLATION, OPERATION & MAINTENANCE MANUAL

Component list

- | | | |
|-------------------|--------------------------|-----------------|
| 1. Stem cap | 7. Bonnet | 13. Wedge |
| 2. Bolt | 8. Thrust collar | 14. Body |
| 3. Stem | 9. EPDM rubber manchette | 15. Sleeve |
| 4. NBR wiper ring | 10. Bonnet bolt | 16. Shrink hose |
| 5. NBR O-ring | 11. Bonnet gasket | 17. Pipe |
| 6. Bearing | 12. Wedge nut | |

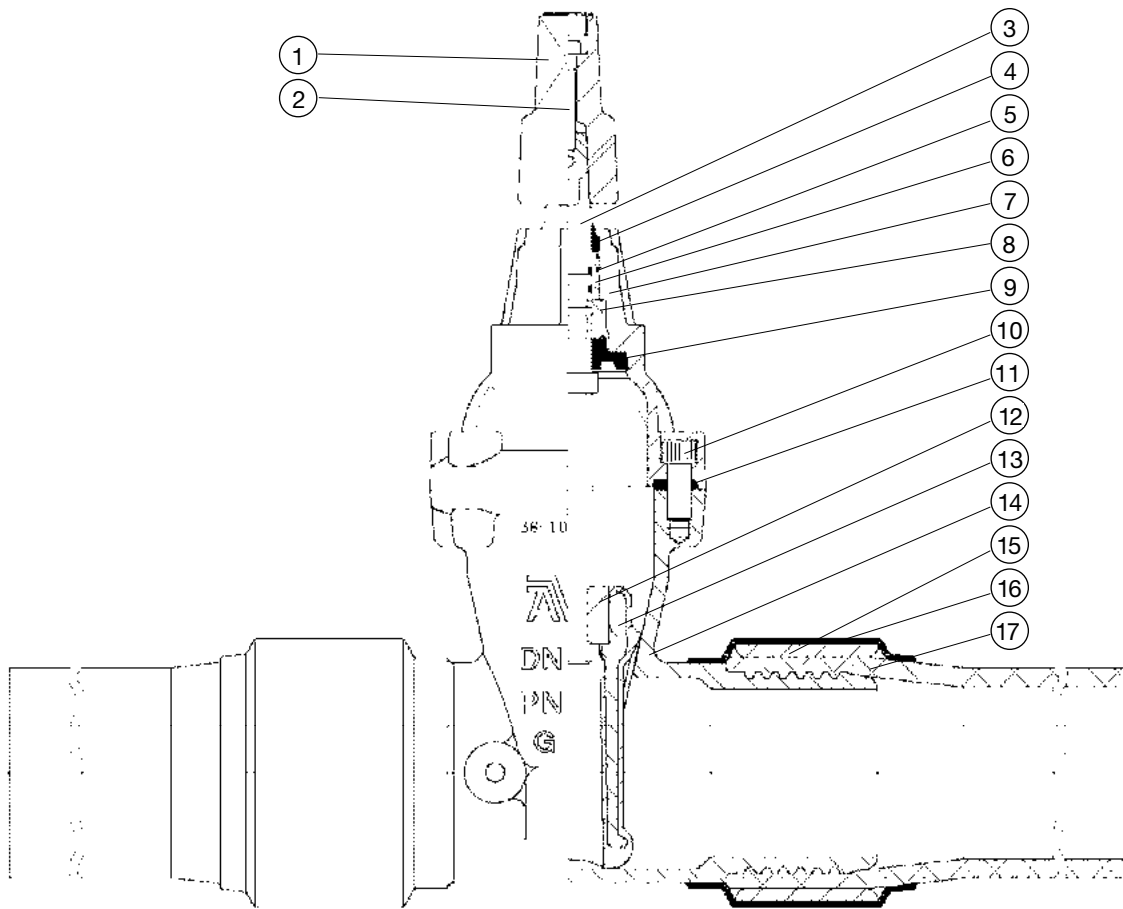

AVK SERIES 36/80 GATE VALVE WITH PE PIPES INSTALLATION, OPERATION & MAINTENANCE MANUAL

4. Maintenance

4.1. General

The valve is designed for underground use with minimum maintenance and requires no lubrication.

4.2 Replacement of Wedge

- a) Isolate valve and ensure there is no pressure in the pipeline.
- b) Adjust handwheel or stem cap to put the wedge into a slightly open position.
- c) Remove hot melt to expose bonnet bolts (10) then remove bolts.
- d) Lift the entire bonnet assembly and wedge (13) clear of valve body (14).
- e) Unscrew wedge (13) from the stem (3).
- f) Fit new wedge by reversing step 'e', take care that the wedge is in a mid-position on the stem so that when refitting it will be clear of the base and body.
- g) Replace bonnet gasket (11). It is suggested that the bonnet bolts (10) are inserted into the bonnet holes first and then the gasket (11) is fitted over them. The whole bonnet assembly can now be refitted onto the body (1).
- h) Tighten the bonnet bolts (10) following a diagonal sequence and using a torque wrench set at 20 Nm to 40 Nm. Re-set the torque wrench at 75 Nm for stainless steel bolts (60 Nm for Grade 8.8 and 12.9 bolts). Tighten the bolts following a circumferential sequence.
- i) Check integrity of seal by re-charging the main.
- j) We recommend that the bonnet bolt heads are re-sealed to prevent corrosion. Ensure the sealant is water resistant by using, for example, a silicone type sealant.